



Algas-SDI™

...Innovative liquid vaporizing and gas mixing solutions

ISO 9001
Certified

Vaporaire®

Venturi LPG/Air mixer; Models V7.0 through V250.0



With Tank



Without Tank

- Provides an LPG/Air mixture to supplement or replace natural gas.
- Connects directly to existing natural gas fuel lines.
- Mixed gas delivery pressures available up to 15 psig for propane and 8 psig for butane without air assist.
- Mixed gas delivery pressures available up to 40 psig with air assist.
- Available with or without accumulator tank.
- No modifications to your burner equipment are necessary.
- No orifices to change and no sooting or fouling of combustion equipment.
- Complies with Class I, Division 1, Group D requirements.
- Compact and easy to service.
- 100% Turndown.

Specifications

Capacity [†] Million BTU/Hr.	Delivery Pressure ^{††}						LPG Vapor Inlet (FNPT)	Outlet with tank	Outlet without Tank
	5 psig	8 psig	10 psig	12 psig	15 psig***	15-40 psig [▲]			
7	V7-5 ^{†††}	V7-8 ^{†††}		V7-12 ^{†††}			1"	4"-150# FLG	6"-150# FLG
10.5	V10.5-5 ^{†††}	V10.5-8 ^{†††}		V10.5-12 ^{†††}			1"	4"-150# FLG	6"-150# FLG
13			V13-10 ^{†††}				1"	4"-150# FLG	6"-150# FLG
14	V14-5 ^{†††}	V14-8 ^{†††}		V14-12 ^{†††}	V14-15 ^{†††}		1"	4"-150# FLG	6"-150# FLG
21	V21-5	V21-8		V21-12			1"	4"-150# FLG	6"-150# FLG
26			V26-10				1"	4"-150# FLG	6"-150# FLG
28	V28-5	V28-8		V28-12	V28-15	V28-PA	1"	4"-150# FLG	6"-150# FLG
35	V35-5	V35-8		V35-12			1½"	4"-150# FLG	6"-150# FLG
39			V39-10				1½"	4"-150# FLG	6"-150# FLG
42	V42-5	V42-8		V42-12	V42-15	V42-PA	1½" **	4"-150# FLG	6"-150# FLG
52			V52-10				1½"	4"-150# FLG	6"-150# FLG
56	V56-5	V56-8		V56-12	V56-15	V56-PA	1½" **	4"-150# FLG	6"-150# FLG
65			V65-10				2"	4"-150# FLG	6"-150# FLG
70	V70-5	V70-8		V70-12	V70-15	V70-PA	2"	4"-150# FLG	6"-150# FLG
78			V78-10				2"	4"-15-# FLG	6"-150# FLG
84	V84-5	V84-8		V84-12	V84-15	V84-PA	2"	4"-150# FLG	6"-150# FLG
100	V100-5	V100-8		V100-12 [♦]	V100-15 [♦]	V100-PA ^{♦♦}	2"	6"-150# FLG	8"-150# FLG
125	V125-5	V125-8		V125-12		V125-PA	2½"	6"-150# FLG	8"-150# FLG
150	V150-5	V150-8		V150-12	V150-15	V150-PA	3"	6"-150# FLG	8"-150# FLG
175	V175-5 ^{♦♦♦}	V175-8		V175-12		V175-PA	3"	6"-150# FLG	8"-150# FLG
200	V200-5	V200-8		V200-12		V200-PA ^{♦♦}	3"	8"-150# FLG	10"-150# FLG
225	V225-5	V225-8		V225-12		V225-PA	3"	8"-150# FLG	10"-150# FLG
250	V250-5	V250-8		V250-12		V250-PA	3"	8"-150# FLG	10"-150# FLG

* Models V21-5 and V28-5 have a 1-½"NPT vapor inlet.

** Models V42-5 and V56-5 have a 2"NPT vapor inlet.

*** All 15 PSI models use a 640 gallon accumulator tank.

▲ PA - Pressure assist. Only available without tank.

† Mixing capacities shown are approximate and may be adjusted by increasing or decreasing the LPG motive pressure. Capacity ratings based on a mixed gas gross heating value of 1450 BTU/SCF ± 5% with commercial grade propane.

†† Delivery pressures shown are valid up to 2000ft elevation.

††† Only available with accumulator tank. See ME mixer specification sheet.

♦ 6" Outlet.

♦♦ 8" Outlet.

♦♦♦ 10" Outlet.

Contact factory for information regarding applications at higher elevations.

Contact factory for shipping weights.

Features

- Solid state progressive sequencer performs pre-programmed logic On/Off switching functions to accurately match each venturi to any flow demand (21-250 MMBTU/hr) (Bellows type pressure switch provided on 7-14 MMBTU/hr models).
- Adjustable mixed gas delivery pressures are available between: 4-5 psig, 6-8 psig, 9-10 psig, 11-12 psig, and 13-15 psig. Consult factory for adjustable ranges on air assist.
- Accumulator tanks are fabricated and stamped in accordance with ASME Unfired Pressure Vessel Code, Section VIII, Division 1.
- Accumulator tank design pressure: 50 psig and 650°F.

- 100% turndown capability.
- Low vapor pressure safety switch prevents rich mixtures from developing due to inadequate motive pressure.
- High mixed gas pressure safety switch prevents over pressurization of gas accumulator.
- Two or more units can easily be operated in parallel to meet the growing requirements of your business.
- All external metal surfaces are mechanically cleaned, primed, and painted.
- 120V/1ph electrical system (220V/1ph optional).
- Shipped complete with all operating and safety controls.

Options

- Air intake silencers.
- Mixed gas BTU analyzer.
- Cabinet enclosure.

Dimensions

* Contact factory for inlet temperatures exceeding 180°F

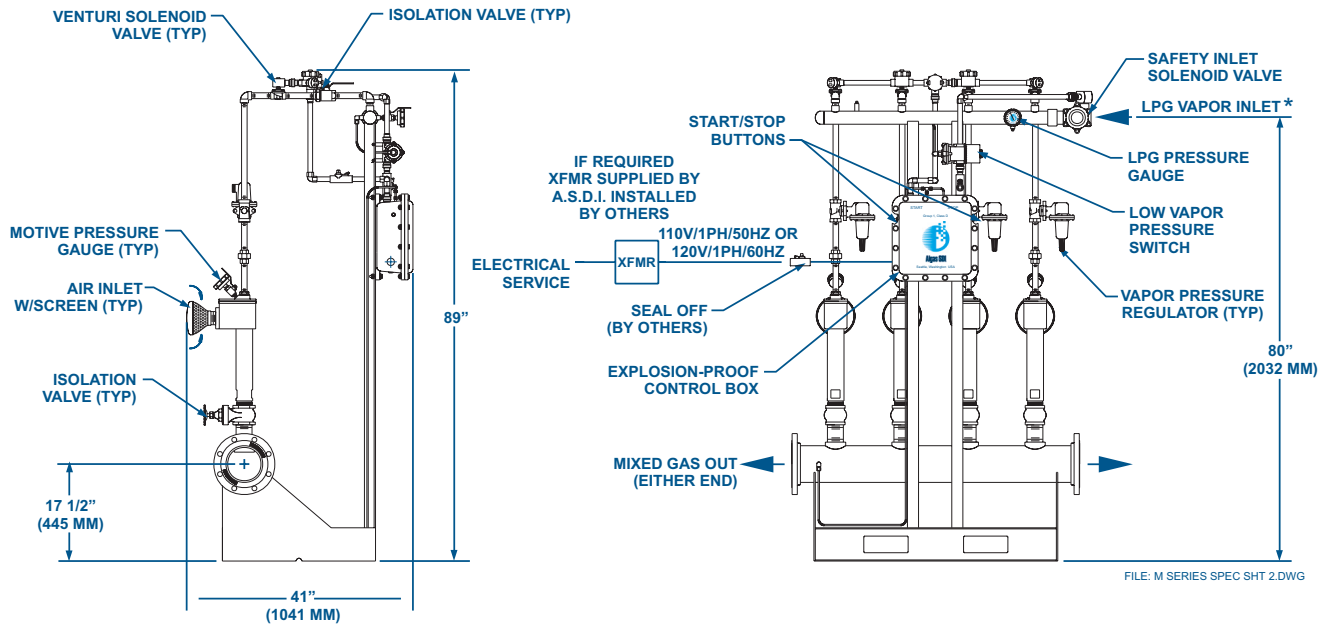
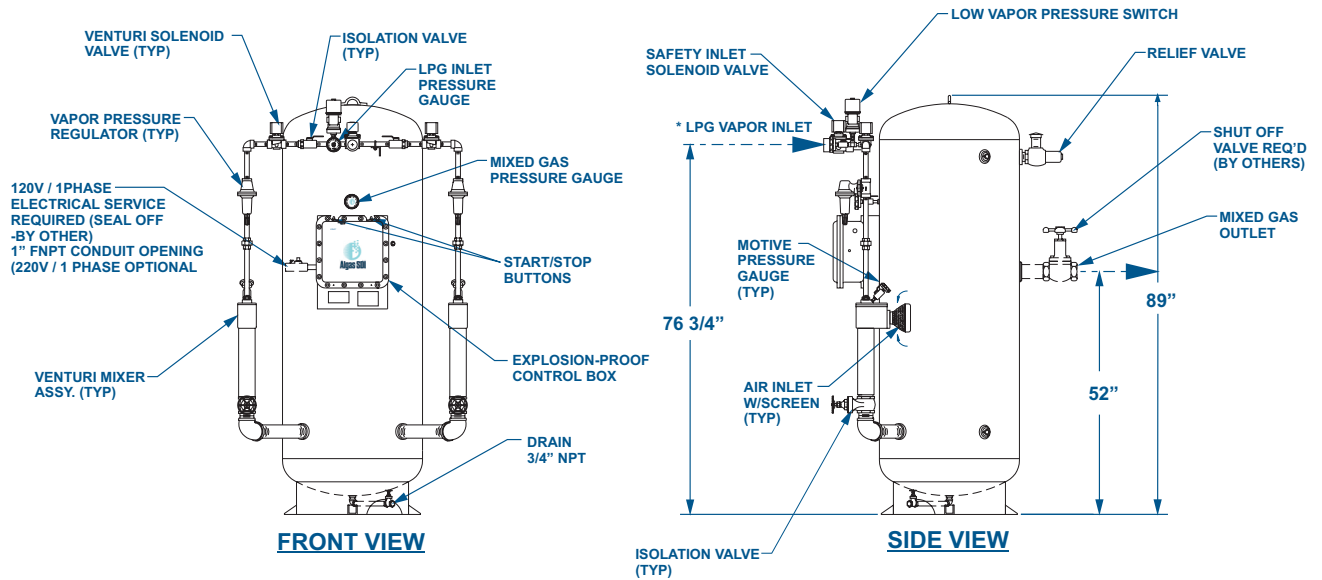

LPG Vapor Pressure Requirement Data

Mixed Air/Propane Delivery Pressure (psig)	Minimum Inlet Vapor Pressure (psig)
Propane	
5	31 - 51
8	70 - 76
10	99 - 109
12	110 - 120
15	160
Butane	
8	95
Pressure Assist	
15 - 40	70 - 90
Contact factory for additional information	

Product improvement is a continuing goal at Algas-SDI. Designs and specifications are subject to change without notice or obligation (contact factory for dimensions on V100 through V250).

NOTES:

1. BY OTHERS
2. INSTALL SYSTEM PER NFPA 58 AND 70 AND OTHER APPLICABLE CODES.
3. NO CHECK VALVES IN LIQUID LINE: LIQUID MUST BE ABLE TO FLOW IN BOTH DIRECTIONS.

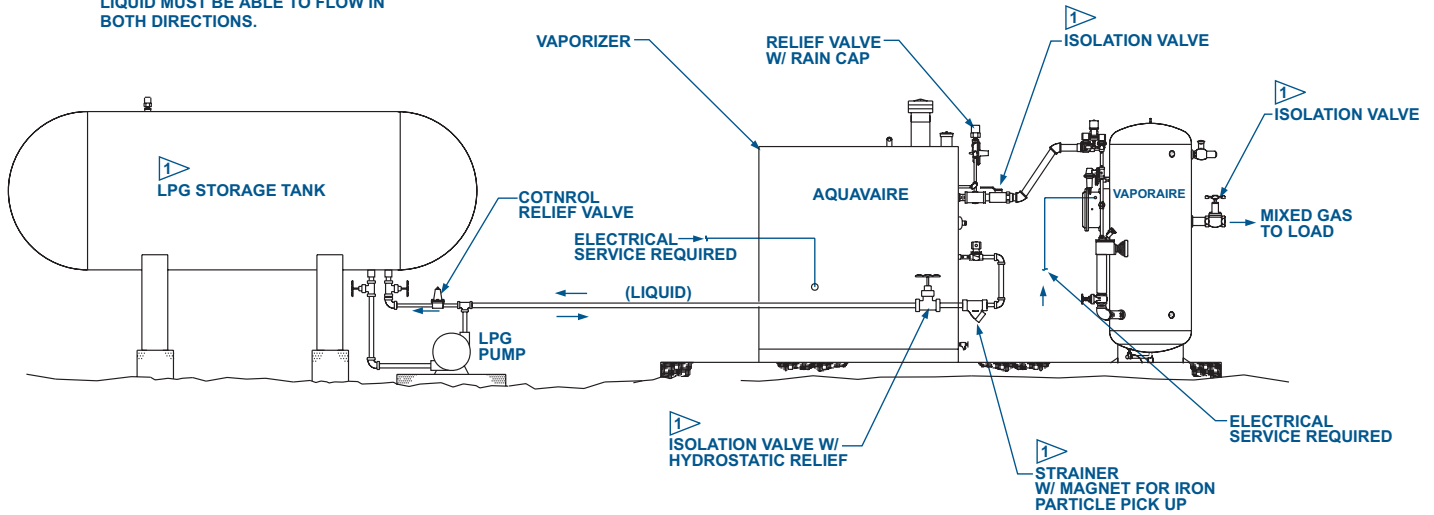

FILE: VAPSPEC2.DWG

VAPORAIRE[®] is a registered U.S. trademark of Algas-SDI.





Offered By:

Power Equipment Company
2011 Williamsburg Road
Richmond, Virginia 23231

T: 804-236-3800

F: 804-236-3882

www.peconet.com

sales@peconet.com